

AB/ABD
AIR BOOSTERS &
SYSTEMS

AB & ABD SERIES AIR BOOSTERS

SC Hydraulic Engineering offers a complete selection of air boosters for almost any application. From economical compact single-acting two and four-to-one models to double-acting two and five-to-one models we can size a unit or system to fit your exact requirement.



The principle of the air booster works much the same as our liquid pumps in which a larger air drive piston is directly connected to a smaller pumping piston. The incoming air from the compressor drives the booster and also feeds the supply to the unit.

Pressures can be boosted up to 500 psi on the single-acting AB-4 and as much as 850 psi on our double-acting ABD-5.



All SC air boosters are pre-lubricated at the factory and should not be used with inline air lubricators. Clean, dry air is very important as any grit, moisture, or foreign matter in the air supply can damage the high pressure components. A coalescing filter is recommended before the air supply and air drive inlet, which can be the same.

Typically, air boosters are used to build up pressures for static holding applications. Under normal, intermittent duty, the air cycling valve should be inspected and re-lubricated after 500,000 cycles. For continuous operation the booster should not be operated at more than 40 cycles per minute and should be inspected and re-lubricated every 150,000 cycles or 60 operating hours.

Typical Applications

- Extra force for small air clamps, roll tensioners, assembly machines and air presses.
- Top off and maintain pressure in die cushions.
- Release spring actuated brakes
- Top off high pressure tires.
- Increase marginal air pressure to valve actuators.
- Increase maximum torque on small air tools.
- Engine air starter systems.

In addition SC Hydraulic Engineering offers four standard air booster systems, which include an air booster, air controls, pressure gauges, high pressure receiver tank., safety relief and high pressure regulator.



Custom booster systems are also available with multiple boosters, special tanks, custom skids, and more. In most cases a custom booster system can be designed, manufactured, tested and shipped in four weeks or less; usually in less time than our competition can ship a standard unit.

Contact us direct, or one of our qualified distributors, with your specific requirements and let us help you with any of your air booster applications.

AB-2 & AB-4 SERIES

The AB Series air booster is a compact, single-acting unit available in 2:1 or 4:1 ratios. This booster is an inexpensive alternative for applications requiring 100-500 psi static holding pressures when low flow is acceptable.

The air drive and supply are the same so no extra plumbing is required and no electrical connections are needed. The compact and lightweight size, and ability to operate in any position, has broad appeal for in-plant, mobile machinery, and OEM applications. The units are pre-lubricated therefore air line lubrication is not required.

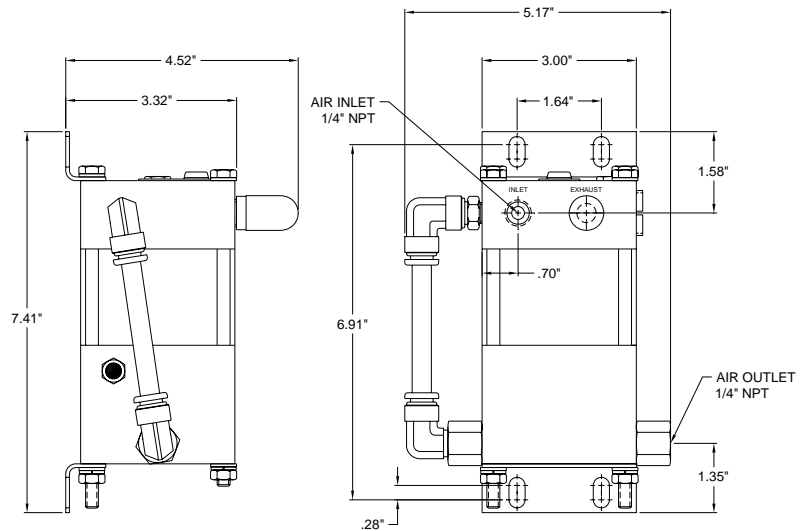

MODEL SELECTION CHART								
Model No.	Maximum Rated Air Supply (Ps)	Maximum Rated Air Outlet (Po)	Connection Ports			Static Outlet Stall Pressure	Actual Area Ratio	Displacement Per Stroke (in3 per cycle)
			Air Drive	Air Inlet	Air Outlet			
AB-2	150 psig	300 psig	1/4" NPT		1/4" NPT	2 Pa	2:1	2.9
	10.3 bar	21 bar						
AB-4	150 psig	600 psig	1/4" NPT		1/4" NPT	4 Pa	4:1	1.4
	10.3 bar	41 bar						

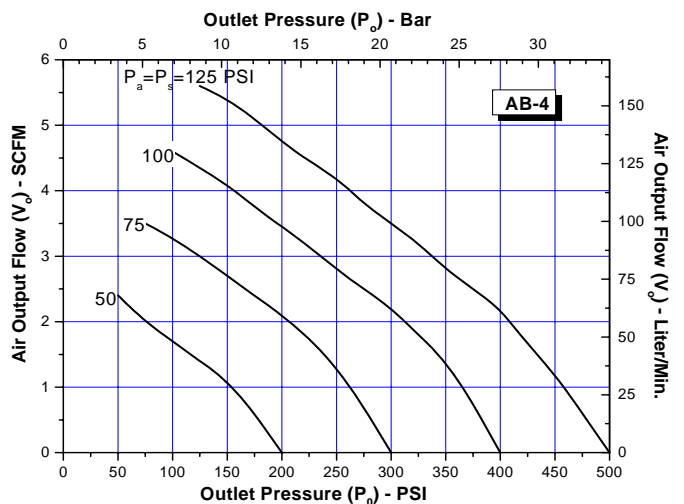
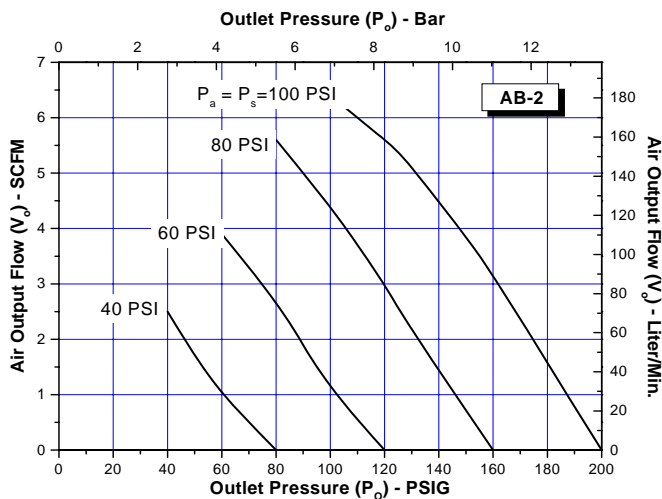

ABD-2 & ABD-5 SERIES



ABD-2 2:1 Ratio Air Booster

The ABD-2 and ABD-5 are double-acting, single stage air boosters in 2:1 and 5:1 ratios. These boosters can supply equipment with added air pressure when plant supplies are depleted due to overuse or under-sizing. The volume available from the boosters is ample for most equipment applications or units can be paralleled for additional capacity.



**ABD-5 5:1 Ratio Air Booster
Shown with Cooling Jacket**

Applications requiring constant cycling should be sized so that the speed of operation does not exceed 40 cycles per minute (CPM). The easiest way to determine if an application meets or exceeds the recommended operating procedures is to fill out the data worksheet on Page 10 OR 11 of the catalog and e-mail (service@schydraulic.com) or fax (714-257-4810) it to our customer service department for sizing assistance.

MODEL SELECTION CHART								
Model No.	Maximum Rated Air Supply (Ps)	Maximum Rated Air Outlet (Po)	Connection Ports			Static Outlet Stall Pressure	Actual Area Ratio	Displacement Per Stroke (in3 per cycle)
			Air Drive	Air Inlet	Air Outlet			
ABD-2	150 psig	300 psig	3/4" NPT	1/2" NPT	1/2" NPT	Pa + Ps	2:1	223
	10.3 bar	21 bar						
ABD-5	150 psig	855 psig	3/4" NPT	1/2" NPT	1/2" NPT	4.7 Pa + Ps	4.7:1	28.2
	10.3 bar	59 bar						

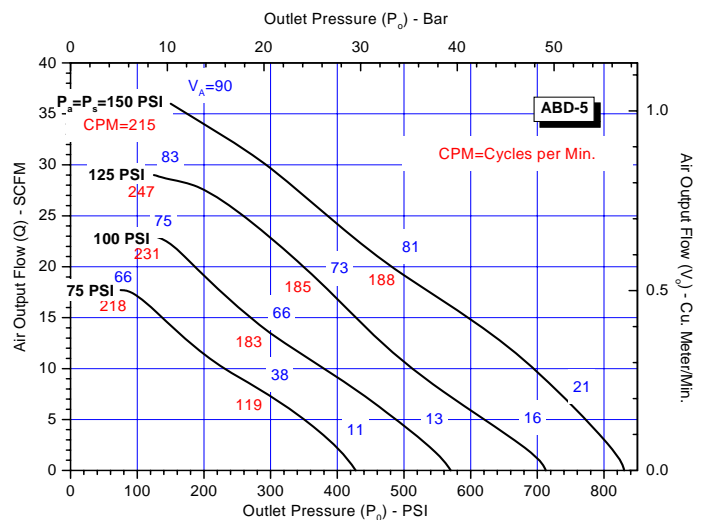
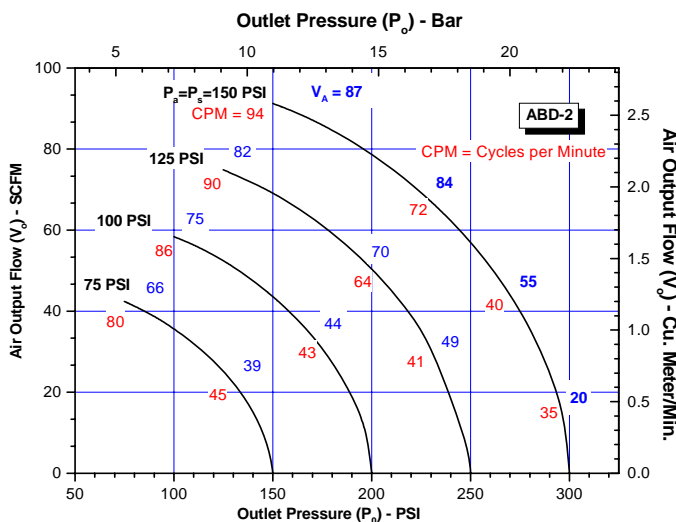

ABD-2 SERIES

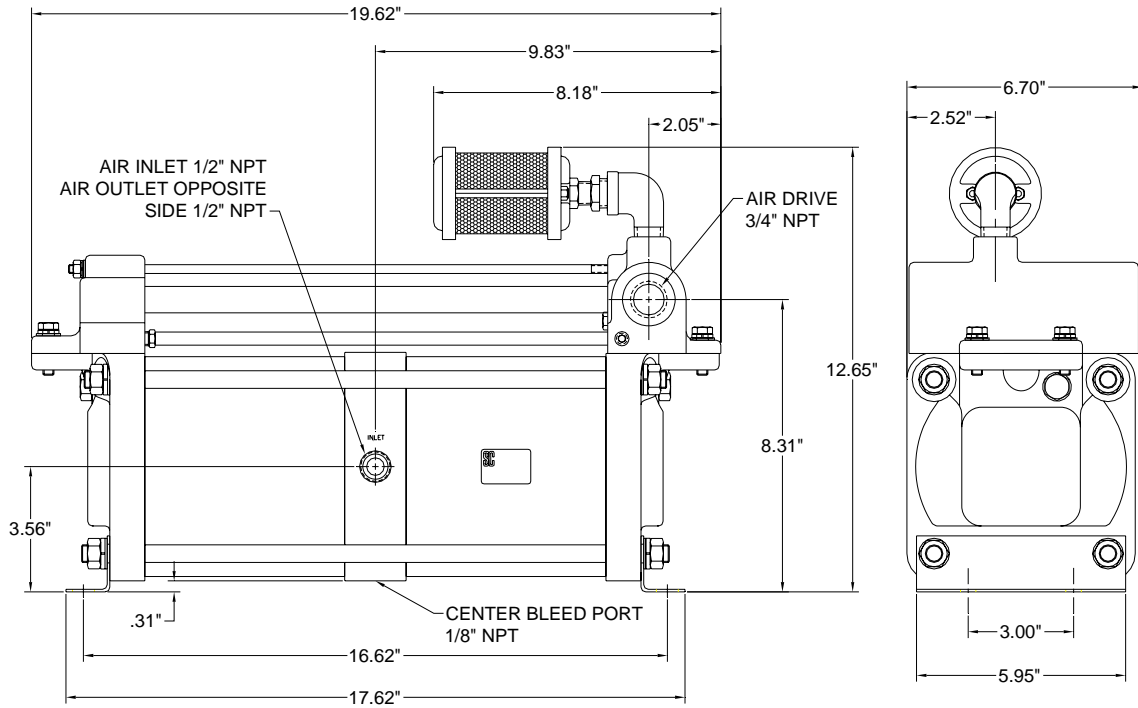

ABD-5 SERIES

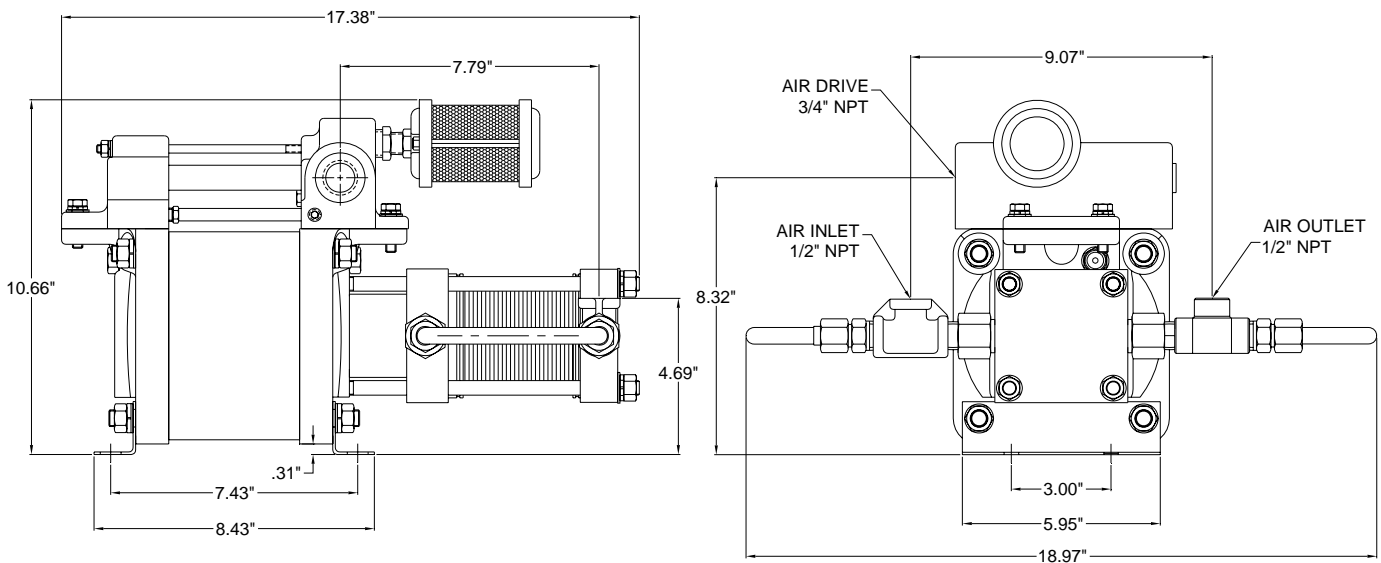

AB-2 & AB-4 SYSTEMS

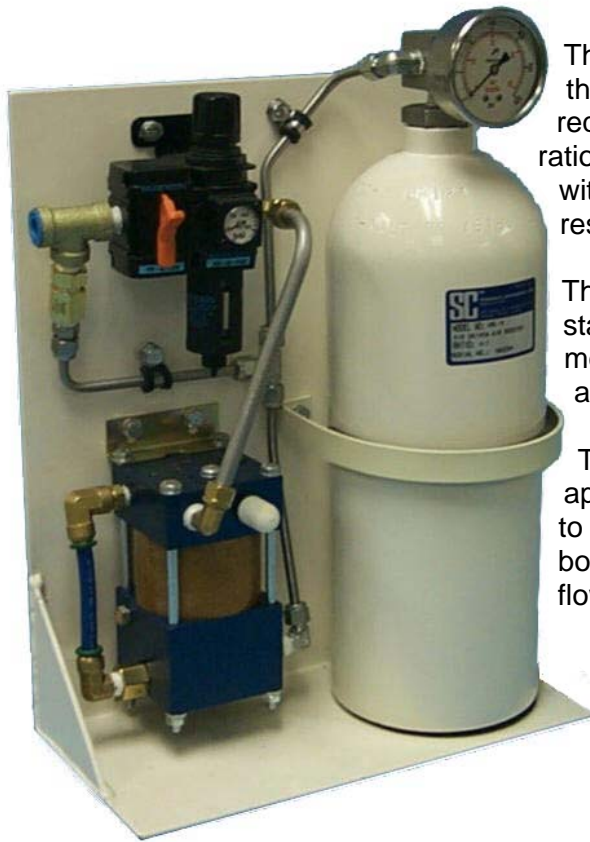

The S10320-AB-2 and S10320-AB-4 Systems provide the most compact sized unit for air booster requirements. Both units consist of either the 2:1 ratio or 4:1 ratio booster, filter/regulator combination with shut-off and air pressure gauge, 200 cubic inch reservoir tank with high pressure gauge.

The components are mounted on a sturdy free standing base and plate. The complete system measures 18 1/4" high by 12 1/2" wide by 6" deep and weighs about 35 pounds

This system is perfect for low flow cycling applications when a reserve of high pressure air (up to 600 psi) is required. The reservoir allows the booster to build up pressure between cycles for higher flow ability than the booster can deliver alone.

S10320-AB-2 2:1 Ratio Air Booster System

Note: Old Model Number is S10306

S10320-AB-4 4:1 Ratio Air Booster System

Note: Old Model Number is S10304

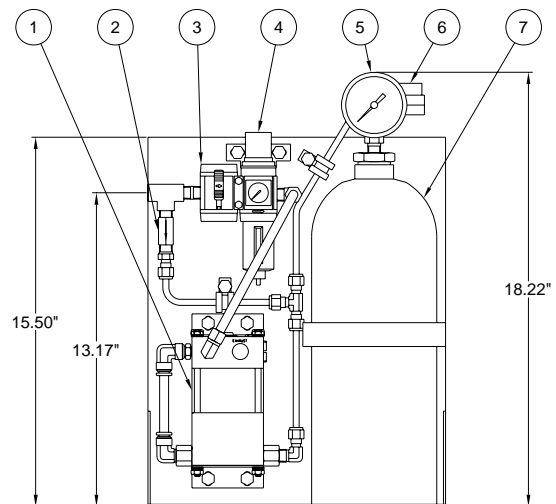
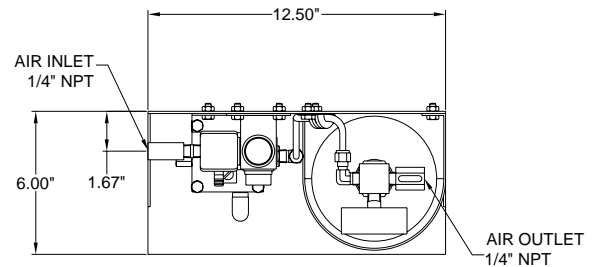

- (1) AB-2 or AB-4 Air Booster
- (2) Inline Check Valve
- (3) Shut-off Valve
- (4) Air Filter/Regulator
- (5) Receiver Pressure Gauge
- (6) Outlet shut-off Valve
- (7) 200 Cu. Inch Receiver

ABD-2 SYSTEM

The S10320-ABD-2 Air Booster System is built for high volume applications requiring up to 250 psi air reserve in a 15 gallon ASME receiver with our double-acting 2:1 ratio air booster.

The booster and receiver is mounted on a heavy duty skid with forklift provisions and weighs approximately 145 pounds. Installation is simple with a 3/4" NPT inlet to an inline filter and a 1/2" NPT outlet high pressure regulator.

The receiver is protected with a safety relief valve and has both receiver and regulator pressure gauges.

This system is a low cost solution when high pressure and relative high volumes of air is required in a pneumatic application. Contact us or one of our authorized distributors for application or sizing assistance.

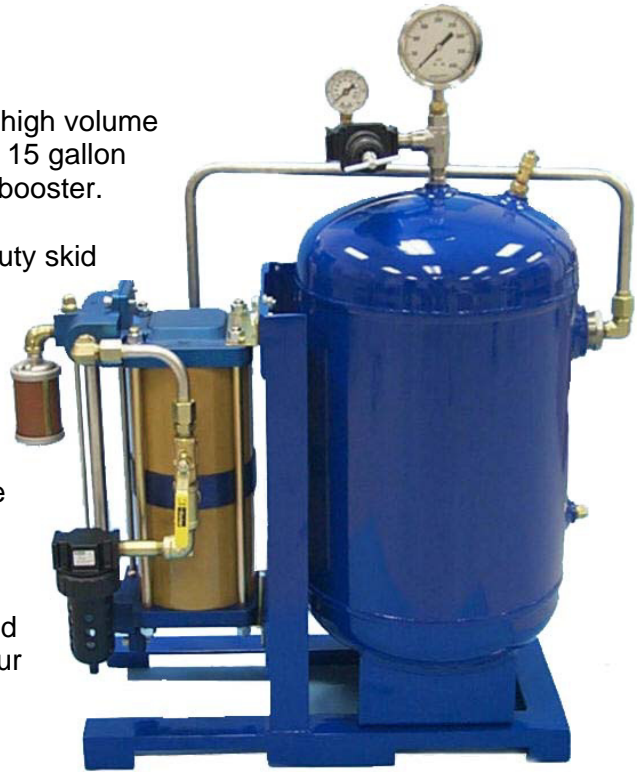

S10320-ABD-2 2:1 Ratio Air Booster System
Note: Old Model Number is S10300

- (1) Tank Drain
- (2) ABD-2 Air Booster
- (3) Inline Filter
- (4) Ball Valve
- (5) Muffler
- (6) Safety Relief Valve
- (7) 15 Gallon ASME Receiver
- (8) High Pressure Regulator

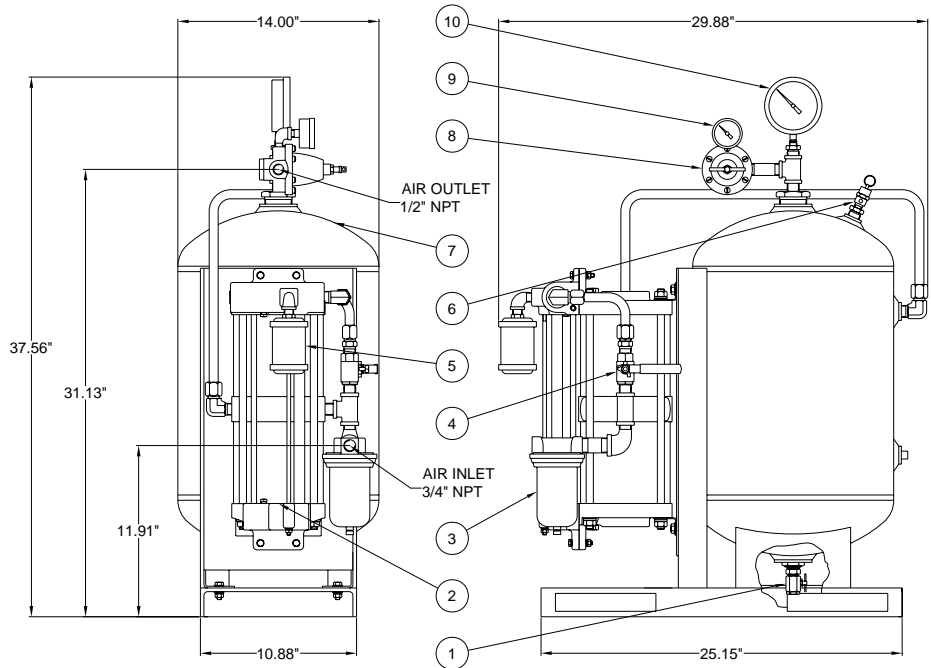

ABD-5 SYSTEM

The S10320-ABD-5 System combines the rugged 5:1 ratio, single-stage, double acting booster with a 600 PSI ASME reservoir for high pressure applications needing a five gallon reserve.

The unit can be mounted either horizontally, as shown, or vertical on a wall or equipment structure. The complete unit weighs approximately 85 pounds.

The system is ready for hook-up to an air supply and includes an inlet filter/regulator with shut-off and gauge, safety relief valve, muffler, high pressure regulator, and high pressure reservoir and outlet pressure gauges.

The S10320-ABD-5 system can save money when requirements need up to a 600 PSI supply of air with reserve capacity. Contact us or one of our authorized distributors for application or sizing assistance.

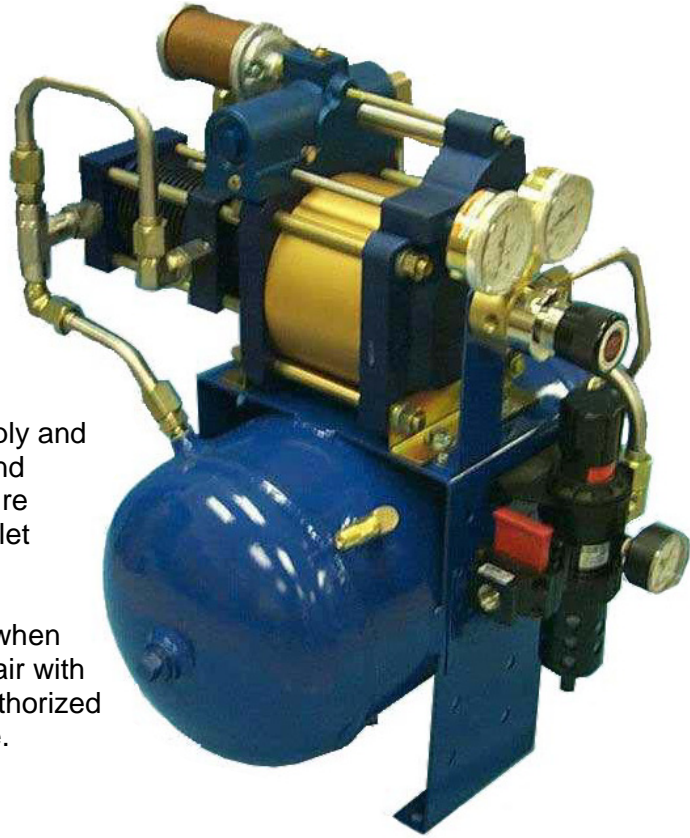

- | | |
|------|--------------------------------|
| (1) | Tank Drain |
| (2) | Filter/Regulator with Shut-off |
| (3) | 5 Gallon 600 PSI ASME Receiver |
| (4) | Inlet gauge |
| (5) | Safety Relief Valve |
| (6) | Muffler |
| (7) | High Pressure Regulator |
| (8) | Receiver Gauge |
| (9) | ABD-5 Air Booster |
| (10) | Outlet Gauge |

S10320-ABD-5 5:1 Ratio Air Booster System

Note: Old Model number is S10301

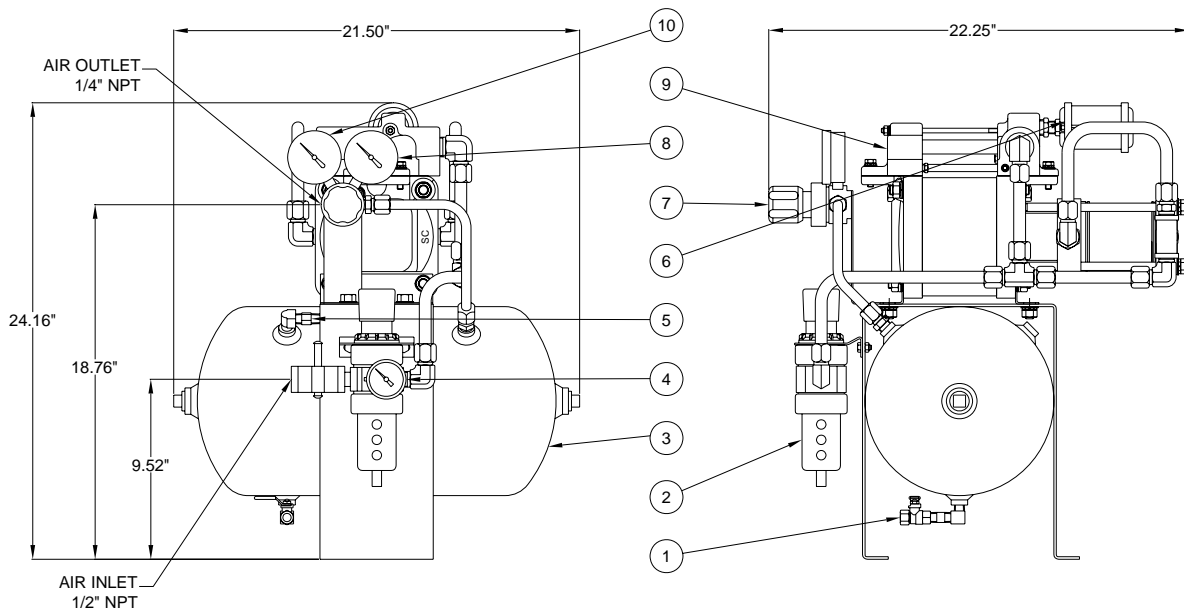

HOW TO ORDER TABLE

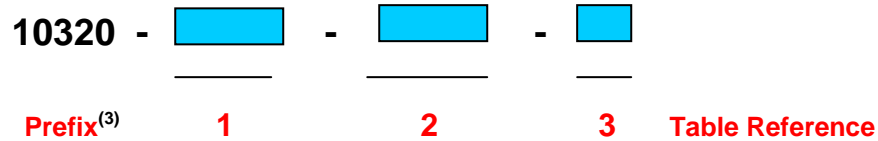

Example #1 Booster Only Selection

AB - M202 - 4

AB Series Single Stage

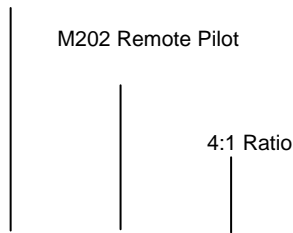

AB - M202 - 4

Example #2 Booster System Selection

S10320 - ABD-M205 - 5

Air Booster System (Add for Systems Only)

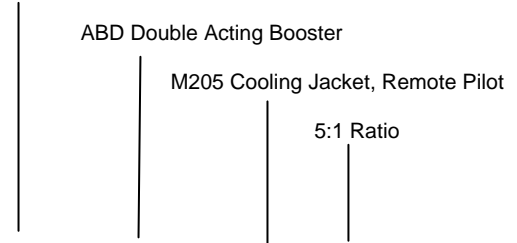

S10320 - ABD - M205 - 5

TABLE 1 ⁽¹⁾ **Gas Booster Series**

AB	Single Stage
ABD	Single Stage Double Acting

TABLE 2 **Modification**

Blank	No Modification
M200	Refrigerant Recovery ⁽²⁾
M201	No Inlet/outlet Plumbing ⁽²⁾
M202	Remote Pilot
M203	No Inlet/outlet Plumbing, Remote Pilot ⁽²⁾
M204	Cooling Jacket ⁽²⁾
M205	Cooling Jacket, Remote Pilot ⁽²⁾
M206	Cooling Jacket, No Inlet/Outlet Plumbing ⁽²⁾
M207	Cooling Jacket, No Inlet/Outlet Plumbing, Remote Pilot ⁽²⁾

TABLE 3 **Pressure Ratio**

2	AB, ABD
4	AB
5	AB, ABD
8	AB

Notes:

1. Do not fill gap on a two digit description.
2. Available on ABD-5 only.
3. Use prefix for systems only.